



Raynor TC200, 8' x 12' in sepia with full view aluminum ranch windows

T H E R M A L  
S A N D W I C H  
C O N S T R U C T I O N

Max. Opening Width	Max. Opening Height	Construction	Surface Texture	Section Thickness	Exterior/ Interior Steel Thickness	End Stile Steel	Insulation (R-Value)	Thermal Break	Exterior Colors	Section Warranty
18'	14'	Steel Sandwich	Stucco	2"	26 ga. (.015") 26 ga. (.015")	18 ga.	Polystyrene (10.25)	Yes	White, Almond ClayTone, BronzeTone, Brown*, Sepia*, Frost White*, Beige* & Custom Powdercoat Colors	1-Year (Any Rust) 10-Year (Delamination)

\*Features the Kynar™ paint process, which provides extended UV protection against fading.



**Weatherseal.**

Bottom weatherseal keeps out the elements.



**Section Joints.**

Vinyl thermal break between interior and exterior skins, along with a section joint seal prevent weather infiltration.



**Hardware.**

TC200 has heavy-duty, hot-dipped galvanized steel sections with an epoxy primer and baked-on polyester finish to resist rust and impact. The rugged, hot-dipped galvanized steel track and steel wheel, ball-bearing rollers assure durable, long lasting performance.



**Windows.**

TC200 windows use 1/8" DSB, insulated glass and are available in five different options: 24" x 8" oval windows (top), full view aluminum ranch (bottom), full view aluminum colonial, standard ranch, and standard colonial.



**Specifications & Drawings.**

Visit us at [www.raynor.com](http://www.raynor.com) for CSI Master Format™ Specifications, Raynor Quick Specs and Standard Drawings

**Construction.**

2" thick door sections are made from high-strength, impact-resistant steel with a thermal core of polystyrene insulation for a 10.25 R-Value.

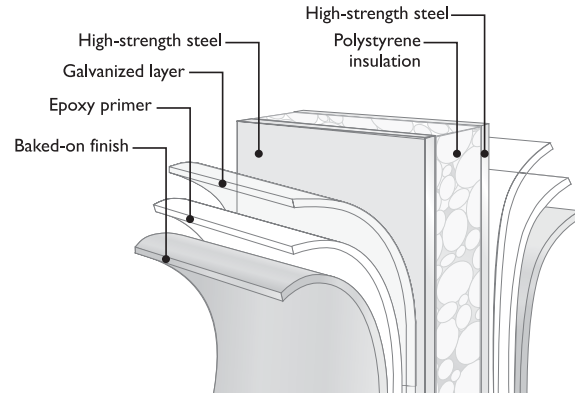

**Finished Interior.**

Two-sided sandwich construction provides TC200 doors with an attractive and durable white finished steel interior.



**CLICK**  
[WWW.RAYNOR.COM](http://WWW.RAYNOR.COM)

**CALL**  
1-800-4-RAYNOR

**FAX**  
1-815-288-7142

Exclusively Distributed By:

**NEPTUNE DOOR CO.**

This information was as complete and factual as possible at the time it was printed. We do, however, reserve the right to make changes in product specifications and availability without notice. Features and options may be different in countries other than the United States. Product colors have been reproduced as well as possible with present commercial printing processes. For absolute accuracy in color matching, use actual product samples.